

BEST ONE

SUBMERSIBLE ELECTRIC PUMPS

in AISI 304 stainless steel



BEST ONE



BEST ONE VOX

Submersible electric pumps for clear water with hydraulic equipment in AISI 304 stainless steel.

APPLICATIONS

- Draining basements, garages, cellars or other flooded enclosed areas
- Supply for garden fountains
- Easy draining of tanks and reservoirs

TECHNICAL FEATURES

- Mechanical seal as standard supply
- New design and renewed styling
- Technologically and mechanically optimised
- Very versatile and suited to fixed and mobile installations
- Equipped with 5 m power cable, type H05 RN-F (single phase) H07 RN-F (three-phase) for use indoors (10 m for use outdoors), with/without float switch

PERFORMANCE CURVES (per ISO 9906 Annex A)

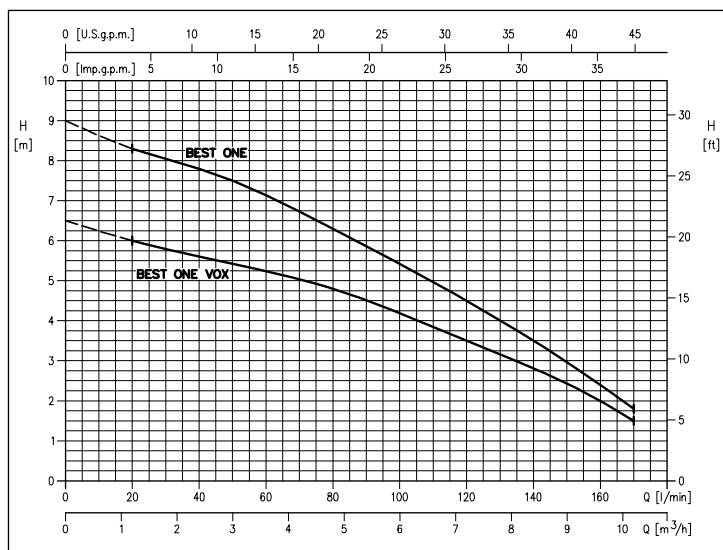

TECHNICAL DATA

- Maximum submersion: 5 m
- Maximum fluid temperature: 50°C
- Maximum solid dimensions:
 - 10 mm
 - 20 mm for the VOX version (Vortex)
- 2 pole asynchronous motor
- Insulation class F
- Protection rating IP68
- Single phase voltage 230V ±10% 50Hz, three-phase voltage 400V ±10%, 50Hz
- Delivery connection: G1¼

MATERIALS

- External jacket, impeller, filter, motor cover, seal disk and motor casing in AISI 304 stainless steel
- Shaft made of AISI 303 stainless steel
- Mechanical seal made of Ceramics/Carbon/NBR

SPECIAL VERSIONS

- MS version with magnetic float switch
- MA version with float switch
- VORTEX version (VOX)

ACCESSORIES (on request)

- Hose connection 1"¼ with hose clamp
- Minimum suction device to 3 mm (BEST ONE M, MA, T only)

For accessories and electrical enclosures, see page 151 onwards

IDENTIFICATION CODE

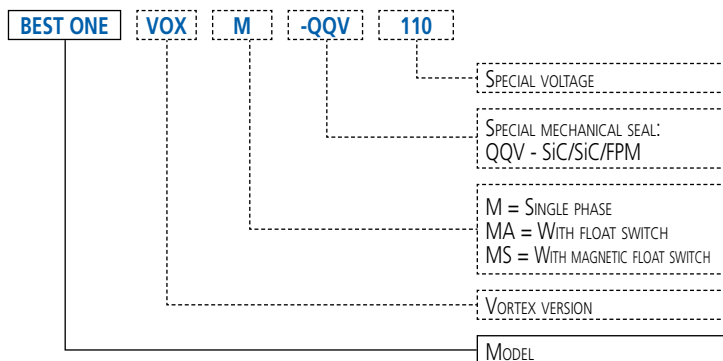

BEST ONE

SUBMERSIBLE ELECTRIC PUMPS in AISI 304 stainless steel

PERFORMANCE TABLE

Model		P ₂		Capacitor		Abs. Curr.		Q=Flow rate					
Single phase 230V	Three phase 400V	[HP]	[kW]	μF	Vc	[A]		l/min 20	40	80	120	160	170
						Single phase	Three phase						
H=Head [m]													
BEST ONE M	BEST ONE	0.33	0.25	8	450	2.3	0.8	8.3	7.8	6.3	4.5	2.4	1.8
BEST ONE VOX M	BEST ONE VOX	0.33	0.25	8	450	2.2	0.8	6.0	5.6	4.8	3.5	2.0	1.5

DIMENSIONS

BEST ONE MA / BEST ONE VOX MA

BEST ONE MS

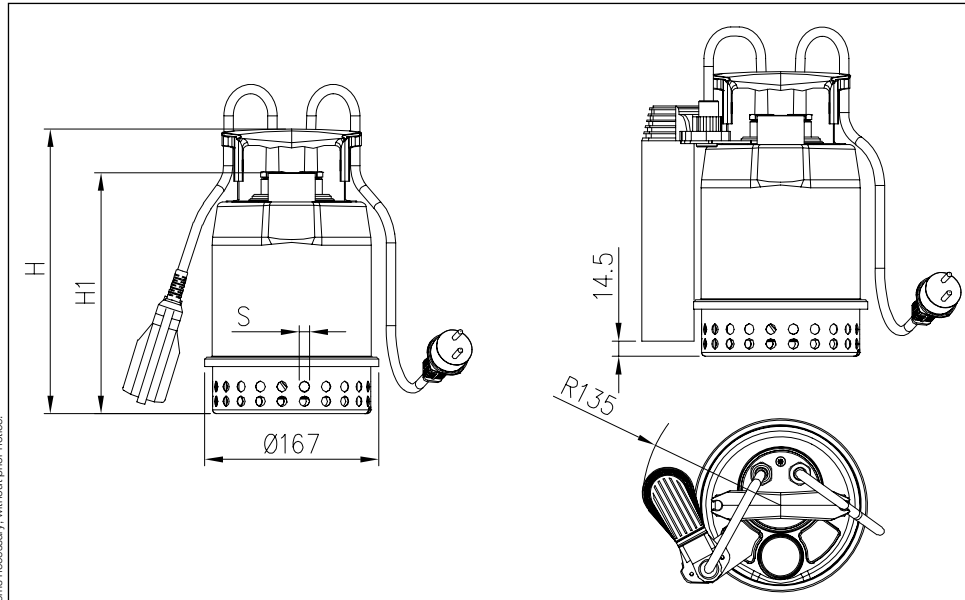

DIMENSIONS CHART

Model	Dimensions [mm]			Weight [kg]
	H	H1	S	
BEST ONE	273	231	10	4.3
BEST ONE M	273	231	10	4.4
BEST ONE MA	273	231	10	4.6
BEST ONE MS	273	231	10	4.8
BEST ONE VOX	304	262	20	4.4
BEST ONE VOX M	304	262	20	4.5
BEST ONE VOX MA	304	262	20	4.7

SECTIONAL VIEW

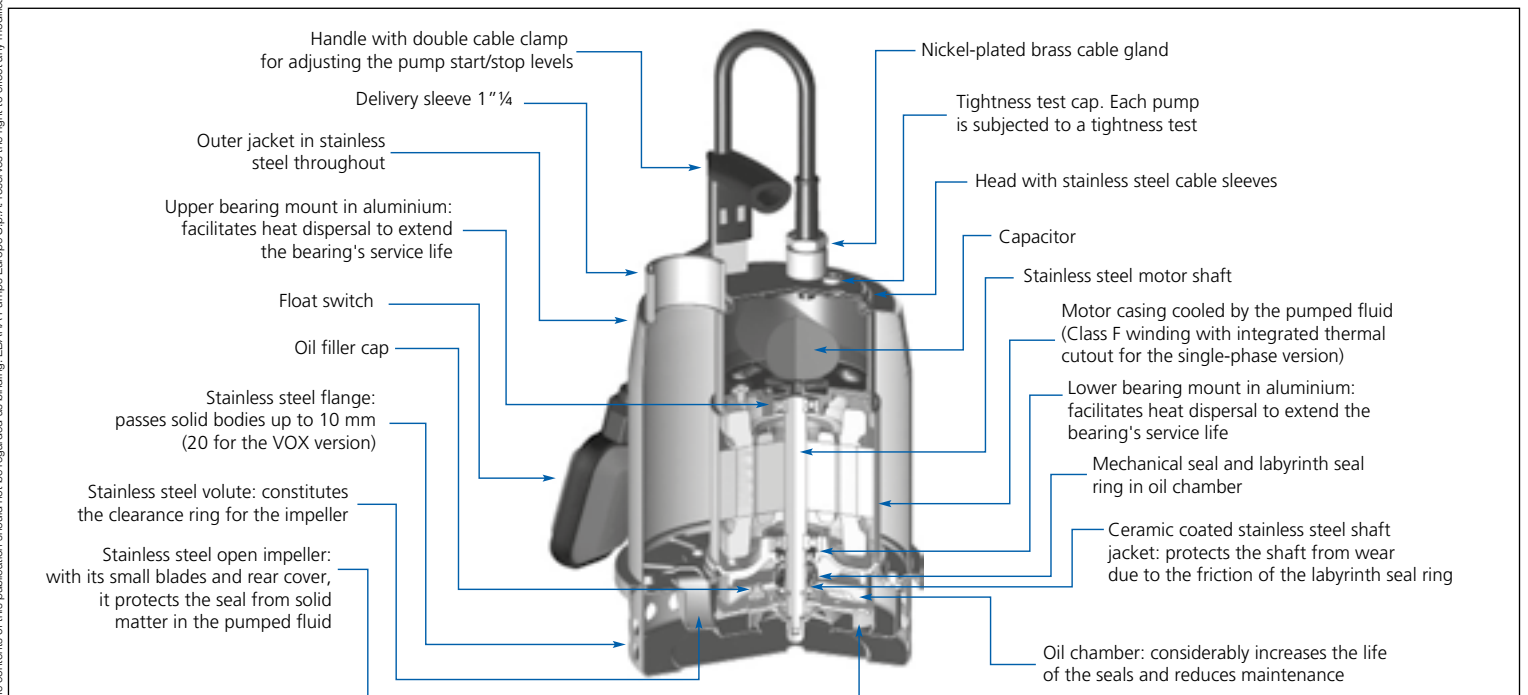

The contents of this publication should not be regarded as binding. EBARA Pumps Europe S.p.A. reserves the right to effect any modification it deems necessary, without prior notice.

BEST ONE

SUBMERSIBLE ELECTRIC PUMPS in AISI 304 stainless steel

INSTALLATION

BEST ONE MA / BEST ONE VOX MA

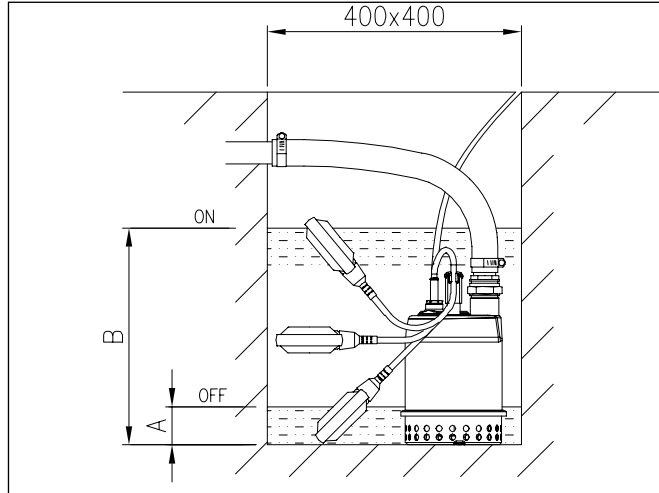

BEST ONE MS

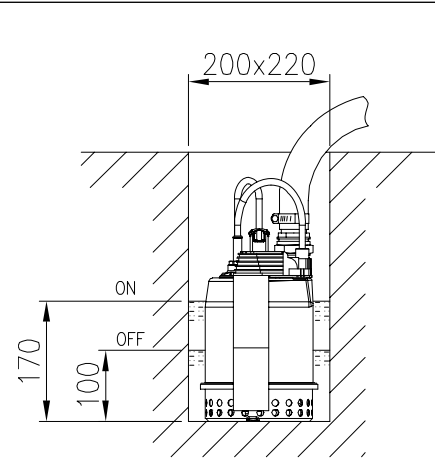

INSTALLATION TABLE

Model	Dimensions [mm]	
	A	B
BEST ONE MA	110	305
BEST ONE VOX MA		330

OPTIONAL

MINIMUM SUCTION DEVICE



The minimum suction device draws the fluid up by as much as 3 mm from the ground (starting from at least 10 mm).

It pressure mounts to the BEST ONE.
The automatic operation of the pump with float switch prevents it from drawing the fluid up to 3 mm.