

# CombiLine

## In-line circulation pump with dry motor



### System characteristics

The CombiLine is a part of the CombiSystem, a family of different pump types having high interchangeability in parts.

Suction and discharge connections are “in-line” allowing easy installation in piping system.

### Applications

The CombiLine is suitable for handling low-viscosity, clean or slightly contaminated liquids non corrosive to cast iron and/or plastic material. For e.g. potable water systems, industrial buildings and also in the agriculture and horticulture.

### Pump specifics

- Suitable for a wide span of duties
- Compact and modular design
- Comes standard with bellows mechanical seal, EN 12756 (DIN 24960)
- Deliverable in single and double speed execution
- Dry shaft construction by means of shaft sleeve
- Specially designed low NPSH suction inlet casing
- High interchangeability in spare parts between different sizes, thus limiting spare parts stock levels

### Technical data

Maximum capacity:	150 m <sup>3</sup> /h
Maximum delivery head:	16 m
Maximum liquid temperature:	140 °C
Maximum operating pressure:	6 bar (ND 6)
Nominal motor speed	10 bar (ND 10)
electric motor:	1450 rpm (50 Hz, 4-pole) 1750 rpm (60 Hz, 4-pole)
2-speed motor:	1450/950 rpm (50 Hz, 4-pole/6-pole)
Dahlander connection:	1750/1150 rpm (60 Hz, 4-pole/6-pole)
Motor protection:	IP 55
Motor voltage:	50 Hz   230/400 V (≤1.5 kW) 400/695 V (≥2.2 kW)
	60 Hz   277/480 V (≤1.5 kW) 480/830 V (≥2.2 kW)
	(other voltages/speeds on request)
Available options:	Steel welding neck flanges Frequency converter

### Materials

<b>Pump casing</b>	Cast iron
<b>Impeller</b>	Cast iron
<b>Motor shaft</b>	Stainless steel
<b>Shaft sealing</b>	Carbon graphite/Ceramic
<b>Shaft sleeve</b>	Bronze
<b>Lantern piece</b>	Cast iron

# Performance data

$n_{nom} = 1500 \text{ rpm}$

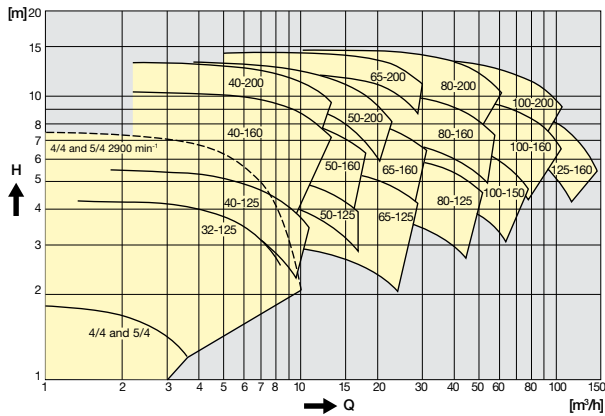

## Dimensions

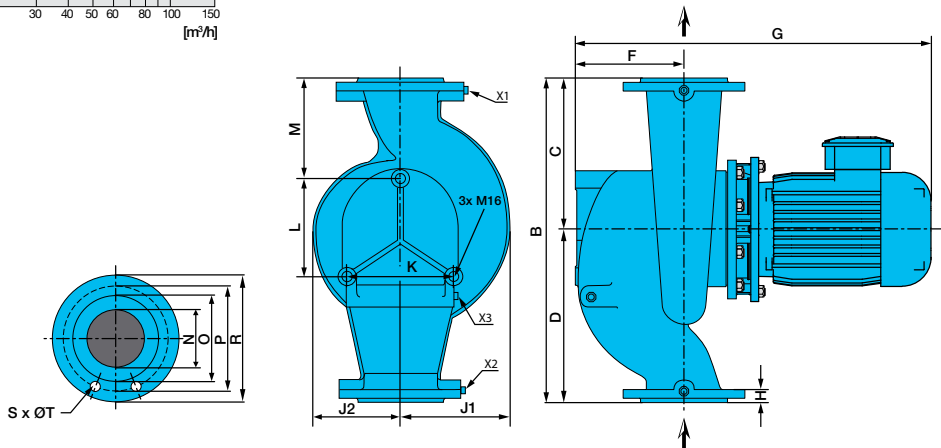

### Flanges:

ND6 according to EN 1092-2 PN6 (DIN 2531 / = ISO 7005 PN6)  
 ND10 according to EN 1092-2 PN10 (DIN 2532 / = ISO 7005 PN10)

CL	B	C	D	F	H <sub>PN6</sub>	H <sub>PN10</sub>	J1	J2	K	L	M	X1**	X2**	X3**	G <sub>max</sub>																			
															kW	Amp	0.13	0.18	0.25	0.37	0.55	0.75	1.1	1.5	2.2	3	4							
32-125	250	125	125	74	19	19	96	85	70	79	80	G ½	G ¼	G ¼	369	-	-	-	-	-	-	-	-	-	-	-	-	-	-	-	-			
40-125	250	125	125	79	18	20	96	85	92	85	75.5	G ½	G ¼	G ¼	377	377	399	-	-	-	-	-	-	-	-	-	-	-	-	-	-			
40-160	320	160	160	77	18	20	114	105	91	72.5	118.5	G ½	G ¼	G ¼	-	-	396	396	420	-	-	-	-	-	-	-	-	-	-	-	-			
40-200	360	180	180	76.5	18	20	138	129	93.5	105	124	G ½	G ¼	G ¼	-	-	-	-	420	420	-	-	-	-	-	-	-	-	-	-	-			
50-125	280	140	140	86	18	22	108	89	105	76.5	99	G ½	G ¼	G ¼	-	-	406	406	-	-	-	-	-	-	-	-	-	-	-	-	-			
50-160	340	170	170	87.5	18.5	22.5	120	106.5	107.5	85	127.5	G ½	G ¼	G ¼	-	-	-	410	410	434	-	-	-	-	-	-	-	-	-	-	-	-		
50-200	380	190	190	85.5	18.5	22.5	136.5	126.5	107	108.5	138.5	G ½	G ¼	G ¼	-	-	-	-	-	432	452	-	-	-	-	-	-	-	-	-	-	-		
65-125	340	170	170	115	18	22	120	100	127.5	101	121	G ½	G ¾	G ¾	-	-	437	437	461	-	-	-	-	-	-	-	-	-	-	-	-	-		
65-160	340	170	170	106.5	18	22	135	113	124	88.5	128.5	G ½	G ¾	G ¾	-	-	-	-	453	453	473	-	-	-	-	-	-	-	-	-	-	-		
65-200**	440	220	220	133.5	--	21	135	113	133.5	102.5	169.5	G ¾	G ¾	G ¾	-	-	-	-	-	-	489	514	-	-	-	-	-	-	-	-	-	-		
80-125	360	180	180	130	20	24	143	109	143	124	118.5	G ¾	G ¾	G ¾	-	-	-	-	481	481	501	-	-	-	-	-	-	-	-	-	-	-		
80-160	400	200	200	131	20.5	24.5	147	123	146.5	127	136.5	G ¾	G ¾	G ¾	-	-	-	-	-	-	512	537	568	-	-	-	-	-	-	-	-	-		
80-200**	530	265	265	113	--	22	166	140	151	139	192	G ¾	G ¾	G ¾	-	-	-	-	-	-	-	498	529	529	-	-	-	-	-	-	-	-	-	
100-150*	560	280	280	148	18	--	189.5	140.5	105.5	116	239	--	--	--	-	-	-	-	504	528	549	-	-	-	-	-	-	-	-	-	-	-	-	
100-160	560	260	300	187.5	21	27	188.5	150	184.5	170	172.5	G ¾	G ¾	G ¾	-	-	-	-	-	-	-	585	616	616	-	-	-	-	-	-	-	-	-	
100-200	590	280	310	171	27	27	194.5	162.5	195	169	192.5	G ¾	G ¾	G ¾	-	-	-	-	-	-	-	-	593	593	612	-	-	-	-	-	-	-	-	-
125-160**	750	375	375	247	--	26	219	173.5	225	195	280	G ¾	G ¾	G ¾	-	-	-	-	-	-	-	-	675	675	694	-	-	-	-	-	-	-	-	-

\* - only available according to EN 1092-2 PN6  
 \*\* - only available according to EN 1092-2 PN10

### External thread connection

CL	Thread	B	C	D	F	H	J1	J2	G <sub>max</sub>	
									kW	1500rpm
4/4	G 1 ½	180	90	90	31.5	9	69	62	300	300
5/4	G 2	180	90	90	31.5	9	69	62	300	300

### DIN 2632 ND10

N	O	P	R	SxØT
32	78	100	140	4x18
40	88	110	150	4x18
50	102	125	165	4x18
65	122	145	185	4x18
80	138	160	200	8x18
100	158	180	220	8x18
125	188	210	250	8x18

### DIN 2631 ND6

N	O	P	R	SxØT
32	78	90	140	4x14
40	80	100	130	4x14
50	90	110	140	4x14
65	110	130	160	4x14
80	128	150	190	4x18
100	148	170	210	4x18



**JOHNSON PUMP**

Johnson Pump Water B.V.

